

FMVC3S SERIES

3.3 Vdc VCXO

CERAMIC SMD 5x7

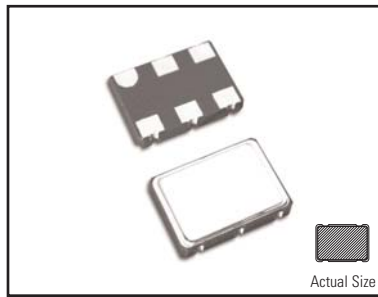

- 3.3 Vdc Supply Voltage
- HCMOS / TTL Compatible
- Small Footprint
- Excellent Stability

SPECIFICATIONS

05 | Issue1 | 012005

Parameter	Specification
Frequency Range	1.54 MHz - 200 MHz
Overall Frequency Tolerance	±20 ppm to ±100 ppm (±50 ppm STD) (Inclusive of Operating Temp., Supply Voltage, & Load.)
Operating Temperature Range	0 to +70°C Std.
Storage Temperature	-55 to +125°C
Supply Voltage (Vdd)	+3.3 Vdc (±0.3 Vdc)
Supply Current (Icc)	30 mA max. @ 1.54 to 23.9 MHz 50 mA max. @ 24.0 to 60.0 MHz 75 mA max. @ 61.0 to 160.0 MHz 90 mA max. @ 161.0 to 200.0 MHz
Symmetry (Duty Cycle)	40/60% Std., 45/55% Available (See Spec. Option S).
Output "0" Level (VOL)	0.3 Vdc max. @ +3.3 Vdc
Output "1" Level (VOH)	3.0 Vdc min. @ +3.3 Vdc
Rise and Fall Time	10 ns max. < 5 ns typical
Linearity	±20% max. Std. , ±10% Available (See Spec. Option L)
Output Load	10 TTL / 15 pF HCMOS < 40.0 MHz 15 pF HCMOS
Pullability	±50 to ±100 ppm typical @ 3.3 Vdd (Select a min. and max. pullability from part number.)
Jitter (typical)	< 10 pico seconds, one sigma
Phase Noise (typical)	10 Hz -75dBc/Hz 100 Hz -110dBc/Hz 1kHz -125dBc/Hz 10kHz -130dBc/Hz 100kHz -140dBc/Hz
Control Voltage (Vc)	Nominal 1.65 Vdc, Range 0.0-3.3 Vdc, Positive Transfer
Aging @ 25°C	±3 ppm max first year

All specifications subject to change without notice.

HALF SIZE 8 PIN DIP

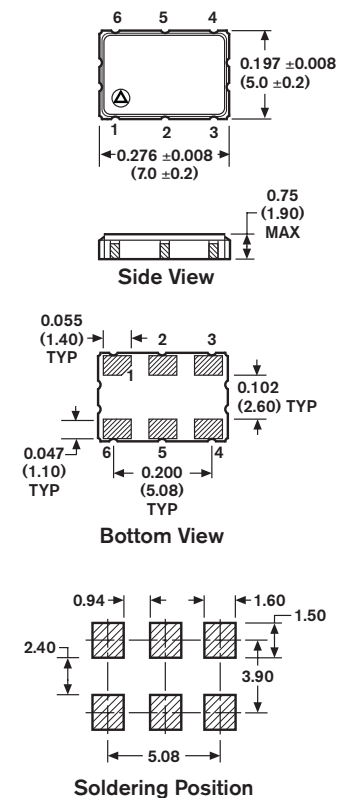

PIN FUNCTION TABLE

Pin	Function
1	Control Voltage
2	Tri-State Control
3	Ground
4	Output
5	N/C
6	+Vdd

Dimensions: $\frac{\text{Inches}}{\text{(mm)}}$

NOTE: Waveforms & Test Circuits on pages 48, 49

Standard Specifications for product indicated in **color**

PART NUMBERING SYSTEM

MARKING: See Page 57, Format H

