

FMVC46 SERIES

5.0 Vdc VCXO

14 PIN DIP



- 5.0 Vdc Supply Voltage
- HCMOS/TTL Compatible
- Wide Pullability Available
- High Frequency

SPECIFICATIONS

05|issue1|110504

Parameter	Specification
Frequency Range	20 kHz - 160 MHz (Std.)
Overall Frequency Tolerance	±20 ppm to ±100 ppm (±50 ppm STD) (Inclusive of Operating Temp., Supply Voltage, & Load.)
Operating Temperature Range	0 to +70°C Std.
Storage Temperature	-55 to +125°C
Supply Voltage (Vdd)	+5.0 Vdc (±0.5 Vdc)
Supply Current (Icc)	30 mA max. @ 20 kHz to 23.9 MHz 50 mA max. @ 24.0 to 60.0 MHz 75 mA max. @ 61.0 to 160.0 MHz
Symmetry (Duty Cycle)	40/60% Std., 45/55% Available (See Spec. Option S).
Output "0" Level (VOL)	0.4 Vdc max. (TTL) 0.5 Vdc max. (HCMOS)
Output "1" Level (VOH)	2.4 Vdc min. (TTL) 4.5 Vdc min. (HCMOS)
Rise and Fall Time	10 ns max. < 5 ns typical
Linearity	±20% max. Std., ±10% Available (See Spec. Option L)
Output Load	10 TTL / 15 pF HCMOS < 40.0 MHz 15 pF HCMOS
Pullability	±100 to ±150 ppm typical, ±75 to ±300 ppm Available. (Select a min. and max. pullability from part number.) Voltage Control Pin 1 Nom. 2.5 Vdc, Range 0.5 to 4.5 Vdc
Jitter (typical)	< 10 pico seconds, one sigma
Phase Noise (typical)	10 Hz -75dBc/Hz 100 Hz -110dBc/Hz 1kHz -125dBc/Hz 10kHz -130dBc/Hz 100kHz -140dBc/Hz
Control Voltage (Vc)	Nominal 2.5 Vdc, Range 0.5-4.5 Vdc, Positive Transfer
Aging @ 25°C	±3 ppm max first year

All specifications subject to change without notice.

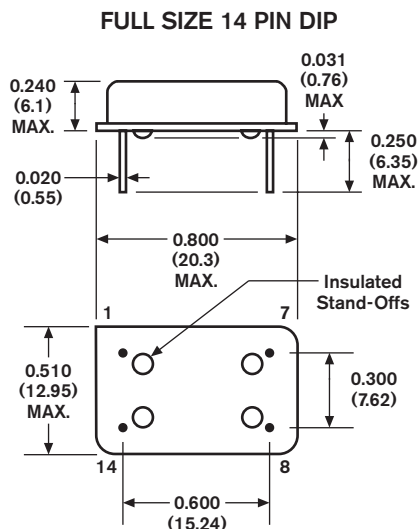

PIN FUNCTION TABLE

Pin	Function
1	Control Voltage (Vc)
7	Case Ground
8	Output
14	Supply Voltage (Vdd)

NOTE: Waveforms & Test Circuits on pages 48, 49

Standard Specifications for product indicated in color

Dimensions: $\frac{\text{Inches}}{\text{(mm)}}$

PART NUMBERING SYSTEM

MARKING: See Page 57, Format G

