

FMVC5S SERIES

5.0 Vdc VCXO

Ceramic SMD 5x7

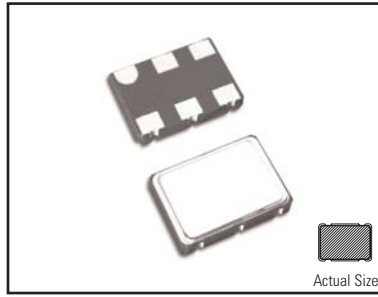

- Miniature, Low Profile
- HCMOS / TTL Compatible
- 5.0 Vdc Supply Voltage
- Excellent Stability

SPECIFICATIONS

05 | Issue 1 | 012005

Parameter	Specification
Frequency Range	1.54 MHz - 200 MHz
Overall Frequency Tolerance	±20 ppm to ±100 ppm (±50 ppm STD) (Inclusive of Operating Temp., Supply Voltage, & Load.)
Operating Temperature Range	0 to +70°C Std.
Storage Temperature	-55 to +125°C
Supply Voltage (Vdd)	+5.0 Vdc (±0.5 Vdc)
Supply Current (Icc)	30 mA max. @ 1.54 to 23.9 MHz 50 mA max. @ 24.0 to 60.0 MHz 75 mA max. @ 61.0 to 160.0 MHz 90 mA max. @ 161.0 to 200.0 MHz
Symmetry (Duty Cycle)	40/60% Std., 45/55% Available (See Spec. Option S).
Output "0" Level (VOL)	0.4 Vdc max. (TTL) 0.5 Vdc max. (HCMOS)
Output "1" Level (VOH)	2.4 Vdc min. (TTL) 4.5 Vdc min. (HCMOS)
Rise and Fall Time	10 ns max. < 5 ns typical
Linearity	±20% max. Std., ±10% Available (See Spec. Option L)
Output Load	10 TTL / 15 pF HCMOS < 40.0 MHz 15 pF HCMOS
Pullability	±100 to ±150 ppm typical @ 5.0 Vdd (Select a min. and max. pullability from part number.)
Jitter (typical)	< 10 pico seconds, one sigma
Phase Noise (typical)	10 Hz -75dBc/Hz 100 Hz -110dBc/Hz 1kHz -125dBc/Hz 10kHz -130dBc/Hz 100kHz -140dBc/Hz
Control Voltage (Vc)	Nominal 2.5 Vdc, Range 0.5-4.5 Vdc, Positive Transfer @5.0 Vdd
Aging @ 25°C	±3 ppm max first year

All specifications subject to change without notice.

CERAMIC SMD

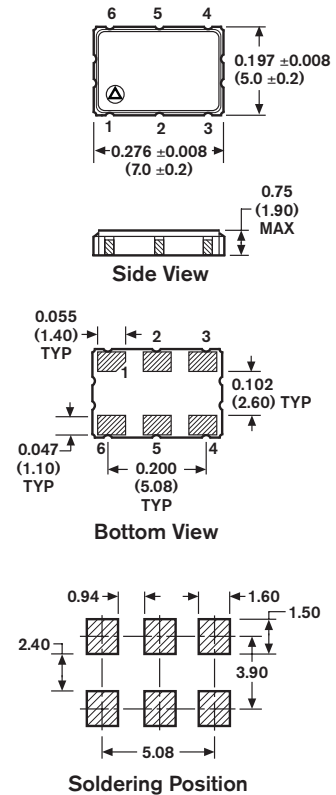

PIN FUNCTION TABLE

Pin	Function
1	Control Voltage
2	Tri-State Control
3	Ground
4	Output
5	N/C
6	+Vdd

Dimensions: $\frac{\text{Inches}}{\text{(mm)}}$

NOTE: Waveforms & Test Circuits on pages 48, 49

Standard Specifications for product indicated in **color**

PART NUMBERING SYSTEM

MARKING: See Page 57, Format H

