

# S53

SERIES - 100 krad SI

Crystal Oscillator | 3.3V | CMOS | 5x3.2mm Ceramic SMD | Space Grade

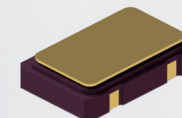

5x3.2 mm Ceramic SMD Package

- Features**
- Ruggedized Design
  - High-Shock & Vibration
  - Industry Standard Package
  - 20 to 60 MHz
  - Shortest Lead Time
  - Smallest Hi-Rel Package
  - ECCN - EAR 99
  - Robust, Rugged, High Shock Crystal Support (3 or 4 point crystal mount)
  - Best Stability Over Temperature
  - Customer Support & Service
  - See S54 Datasheet for 5V Operation

## Electrical SPECIFICATIONS

EM	Dash Number		Frequency Range (MHz)	Supply Current @ 3.3V ±10% (mA)	Rise/Fall Time (tr/tf) max (nsec)	Symmetry min / max (%)	Aging per year max 1/ (ppm)	Stability over Operating Temperature		
	EQM	FM						-55°C to +125°C (ppm)	-40°C to +85°C (ppm)	-20°C to +70°C (ppm)
CODE	CODE	CODE						CODE A	CODE B	CODE C
11	12	13	20 to 29.9	10	4	45/55	±10	±65	±40	±30
14	15	16	30 to 39.9	10	4	40/60	±10	±65	±40	±30
17	18	19	40 to 49.9	15	3	45/55	±10	±75	±50	±40
21	22	23	50 to 60	15	2	40/60	±10	±75	±50	±40

Please Contact Us for Specification Options that are Outside of or beyond those Shown in the Table Above

**CMOS Output, 10 kΩ || 15 pF Load**  
 Output Voltage - Logic "0" is Vcc x 0.1 Vdc  
 Output Voltage - Logic "1" is Vcc is 0.9 Vdc  
 Start-up Time: 10 msec max

**1/ Frequency Aging Limits**  
 Max change over 30 days ±1.5 ppm  
 Max change over 90 days ±3 ppm

### Standard MODEL TYPES

Model	Description
EM: Engineering Models	Same as FM, not with Class K radiation tolerant die commercial screening only
EQM: Engineering Qualification Models	Same as FM with Class K radiation tolerant die, B or C level screening only
FM: Flight Models	Class K radiation tolerant die*, screening & Group A *unless specified otherwise

### Standard PIN CONFIGURATION

Pin Number	Function
1	No Connect or TriState Enable
2	Ground (case)
3	Output
4	Supply V (Vcc)

### How To ORDER

MIL-STD-790 Certified  
 QPL per MIL-PRF-55310  
 ISO 9001:2008  
 Pb-free RoHS Certified

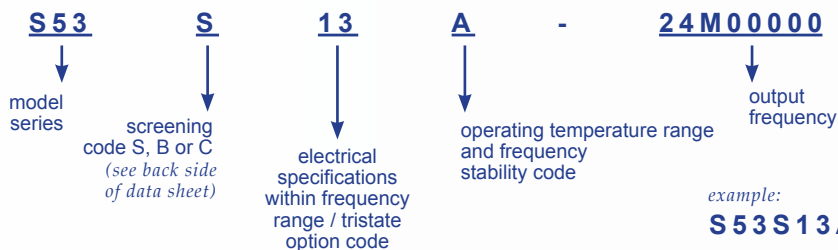

## Mechanical SPECIFICATIONS

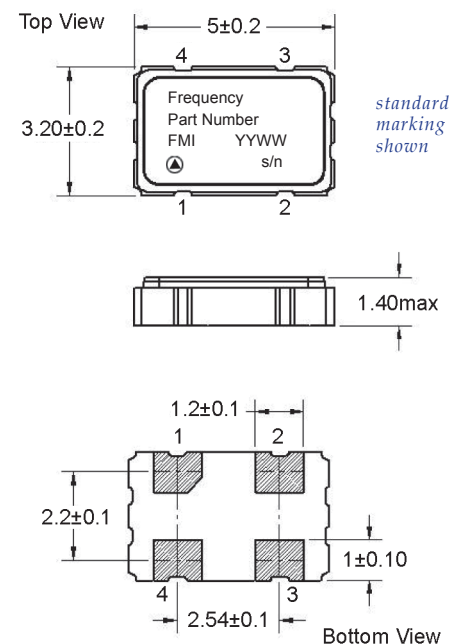

### Recommended Land Pattern

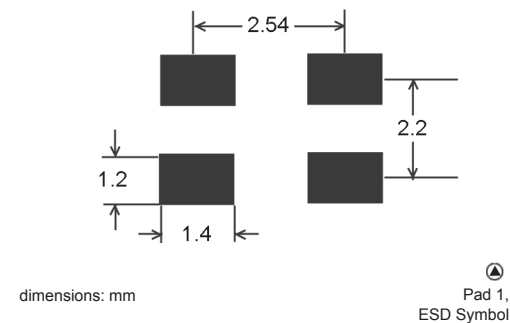

Please request our General Specification for Class S Oscillators Document # QP1100100

Screening- S, B & C LEVELS <small>(per FMI General Specification for Class S Oscillators)</small>			CODE		
Screening	Method	Level:	S	B	C
Non-Destruct Bond Pull	MIL-STD-883, Method 2023		•	•	•
Internal Visual	MIL-STD-883, Method 2017, Class K; Method 2032		•		
	MIL-STD-883, Method 2017, Class H; Method 2032			•	•
Stabilization (Vacuum) Bake	MIL-STD-883, Method 1008, Condition C, 150°C, 48 hours min		•		
	MIL-STD-883, Method 1008, Condition C, 150°C, 24 hours min			•	•
Temperature Cycling	MIL-STD-883, Method 1010, Condition B, 10 Cycles		•	•	
Constant Acceleration	MIL-STD-883, Method 2001, Condition A (Y1 only, 5000 g's)		•	•	
PIND Test	MIL-STD-883, Method 2020, Condition B, 5 passes max		•		
Seal: Fine Leak	MIL-STD-883, Method 1014, Condition A1		•		
	MIL-STD-202, Method 112, Condition C, 111A			•	
Seal: Gross Leak	MIL-STD-202, Method 112, Condition D		•	•	•
Electrical Test	Functional Test Only at +23°C		•	•	•
Marking & Serialization	MIL-STD-1285		•	•	•
Electrical Test	Nominal Vcc & Extremes and Nominal Temp and Extremes		•	•	
Burn-in (load)	+125°C, Nominal Supply Voltage and Burn-in load, 160 hours min		•	•	
Burn-in (no-load)	+125°C, Nominal Supply Voltage and Burn-in load, 48 hours min				•
Interim Electrical	Functional Test Only		•		
Burn-in (load)	+125°C, Nominal Supply Voltage and Burn-in load, 160 hours min		•		
Final Electrical Test	a) Input current, output frequency, output waveform, are tested at +23°C ±2°C		•	•	•
	b) Frequency stability is tested over the specified temperature range; at both extremes and at +25°C at a minimum of 5 temperature increments note: Recording of test data is by lot # and then serial #				
Radiography	MIL-STD-883, Method 2012		•		
Frequency Aging	MIL-PRF-55310, +70°C Condition		•		
Frequency/Temperature Stability	MIL-PRF-55310, Over temperature extremes, 20 points equally spaced		•		
External Visual & Mechanical	MIL-STD-883, Method 2009		•	•	•

note: other options, screening levels and custom test plans available.

### Military Reference Specifications

MIL-PRF-55310 Oscillators, Crystal Controlled, General Specification For  
 MIL-PRF-38534 Hybrid Microcircuits, General Specification For  
 MIL-STD-202 Test Method Standard, Electronic and Electrical Components  
 MIL-STD-883 Test Methods and Procedures for Microelectronics  
 MIL-STD-1686 Electrostatic Discharge Control Program for Protection of Electrical and Electronic Parts, Assemblies and Equipment

### Options Available for FLIGHT MODELS

- Groups B, C, & D per MIL-PRF-38534 (QCI or Qualification)
- Groups B & C per MIL-PRF-55310
- Data Packages
- Swept Quartz Crystals
- Single Lot Date Code
- Source Inspection
- HiRes Photography

### Environmental COMPLIANCE

Environmental	Specification	Method	Condition	
Vibration – Sine	MIL-STD-202	Method 204	Condition D	20g, 10 to 2 KHz
Vibration – Random	MIL-STD-202	Method 214	Condition 1	30g rms, 10 to 2 KHz Random
Shock	MIL-STD-202	Method 213	Condition I	100g, 6 ms, F:1500, 0.5 ms
Seal Test	MIL-STD-883	Method 1014	Condition A1	Fine Leak
Seal Test	MIL-STD-883	Method 1014	Condition C1	Gross Leak
Temperature Cycling	MIL-STD-883	Method 1010	Condition B	10 Cycles Minimum
Constant Acceleration	MIL-STD-883	Method 2001	Condition A	5000g, Y1 Axis
Thermal Shock	MIL-STD-202	Method 107	Condition B	

continued...

Environmental	Specification	Method	Condition	
Ambient Pressure	MIL-STD-202	Method 105	Condition C	
Resistance to Soldering Heat	MIL-STD-202	Method 210	Condition C	
Moisture Resistance	MIL-STD-202	Method 106	with 7B Sub-cycle	
Salt Atmosphere (corrosion)	MIL-STD-883	Method 1009	Condition A (24 hrs)	
Terminal Strength	MIL-STD-202	Method 211	Test Condition D	
Solderability	MIL-STD-883	Method 2003		
Resistance to Solvents	MIL-STD-202	Method 215		

MIL-STD-790 Certified  
 QPL per MIL-PRF-55310  
 ISO 9001:2008  
 Pb-free RoHS Certified

### Materials

1. Package Materials:  
Ceramic, Alumina 90% min
2. External Lead Plating Material:  
Gold plated Kovar, 0.15 µm (60 µ inch) min, over 2.0 µm (80 µ inch) min Nickel

### Products for Space Applications

Contact us for assistance with your specification. We will provide you with the technical support and the required documentation.

Issue3\_08012017



**FREQUENCY MANAGEMENT | International**  
 15302 Bolsa Chica Street  
 Huntington Beach, CA 92649

[FrequencyManagement.com](http://FrequencyManagement.com)

Ph. 714 373 8100  
 Fx. 714 373 8700  
[Sales@FrequencyManagement.com](mailto:Sales@FrequencyManagement.com)